

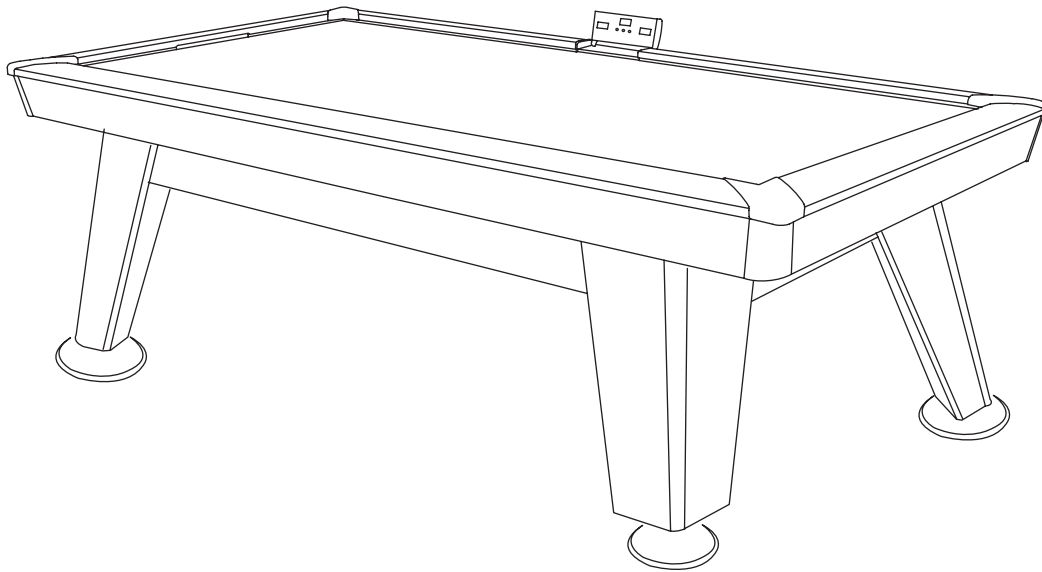

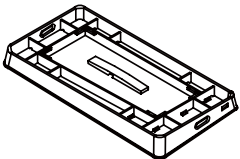





Model Name:Hockey Table
Model Number:6011.037

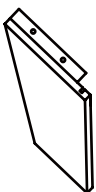

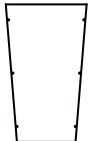
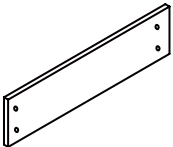
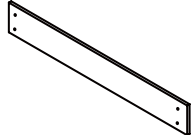

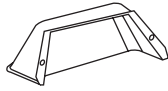



INSTRUCTIONS MANUAL

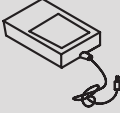

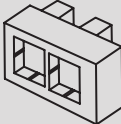

Part List



<p>#1</p>  <p>PLAYFIELD - HOCKEY TABLE 1PC</p>	<p>#2</p>  <p>LEG - PANEL - RIGHT 4PCS</p>	<p>#3</p>  <p>LEG - PANEL - LEFT 4PCS</p>	<p>#4</p>  <p>LEG - BASE 4PCS</p>	<p>#5</p>  <p>LEG INSIDE PANEL 4PCS</p>
<p>#6</p>  <p>LEG END BRACE 2PCS</p>	<p>#7</p>  <p>LEG SIDE BRACE 2PCS</p>	<p>#8</p>  <p>LEG PANEL CORNER 4PCS</p>	<p>#18</p>  <p>LEG LEVELER - 5" 4PCS</p>	<p>#19</p>  <p>GOAL - BOX 2PCS</p>

 Shaded box = pre-installed part

<p>#31</p>  <p>BATTERY BOX 1PC</p>	<p>#32</p>  <p>PUCK CATCHER WIRE 2PCS</p>	<p>#33</p>  <p>LED SCORING 1PC</p>	<p>#34</p>  <p>SCORER BASE BOX 1PC</p>
--	---	--	---

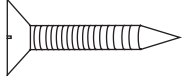
<p>#39</p>  <p>PUSHER - SOMBRERO - RED 2PCS</p>	<p>#40</p>  <p>FELT PAD 2PCS</p>	<p>#41</p>  <p>PUCK - ROUND - RED 2PCS</p>
--	---	---

<p>#47</p>  <p>BOLT - HEX HEAD - 8 X 63.5 MM 16PCS</p>	<p>#48</p>  <p>WASHER - 8 X 19 MM 16PCS</p>	<p>#49</p>  <p>BOLT - ALLEN KE 6.5 X 19 MM 16PCS</p>	<p>#50</p>  <p>WASHER - 6 X 15 MM 16PCS</p>	<p>#51</p>  <p>SCREW - FLAT HEAD - 4 X 45 MM 16PCS</p>
---	--	---	--	---

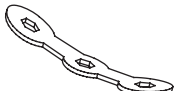
<p>#52</p>  <p>SCREW - ROUND HEAD - 4 X 25 MM 24PCS</p>	<p>#53</p>  <p>SCREW - ROUND HEAD - 4 X 12 MM 20PCS</p>	<p>#54</p>  <p>WRENCH 1PC</p>
--	--	--

STEP 1

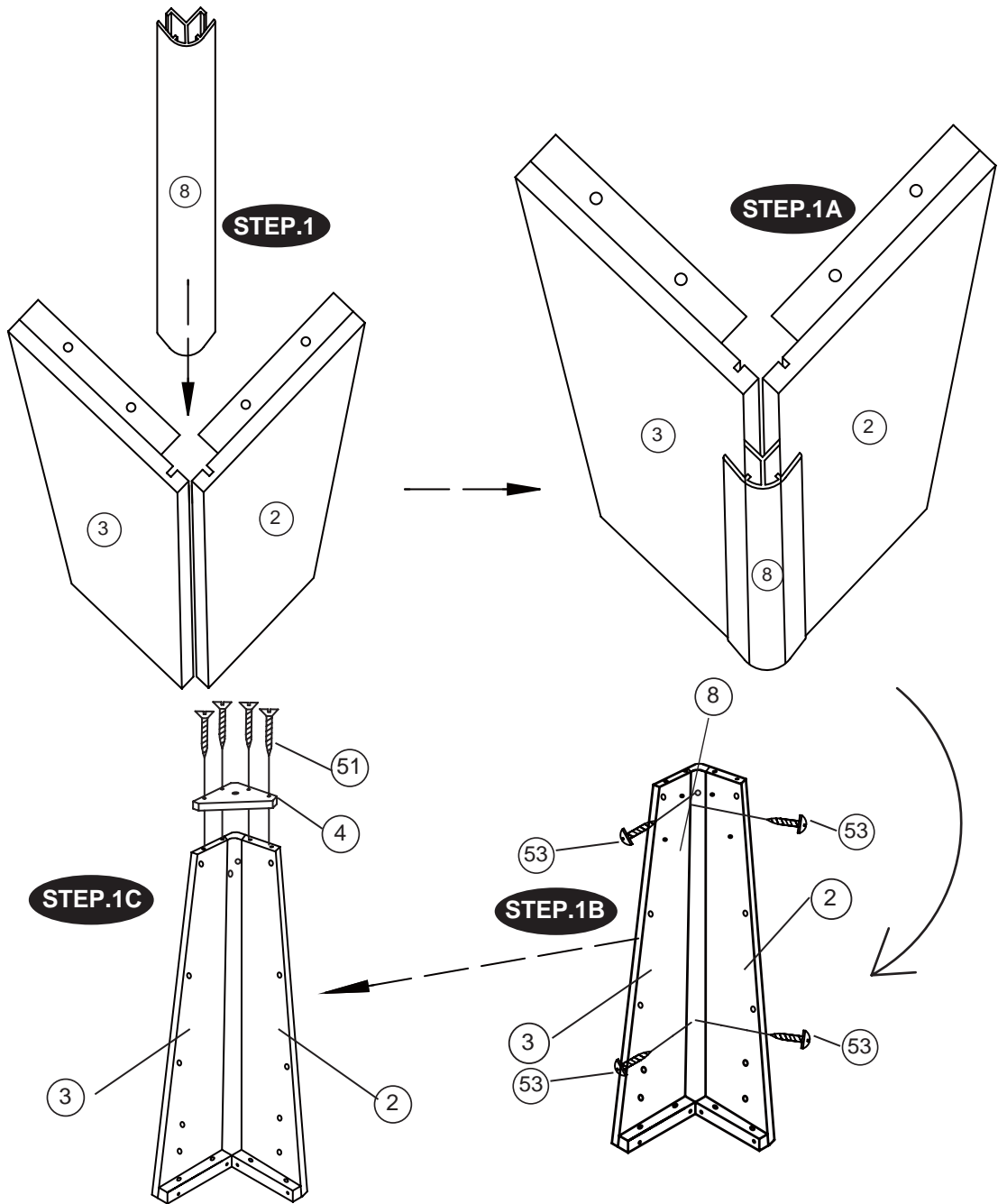
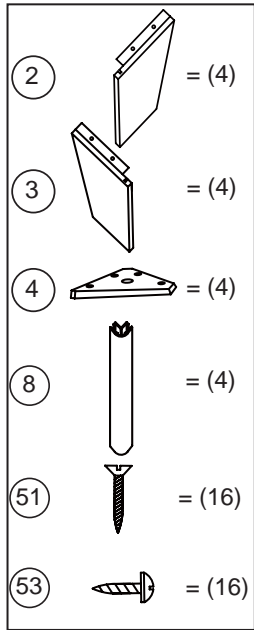

STEP 2:

- Hold two Leg Panels -Right and Left (#2 and #3). See Step.1.
- Slide one Leg Panel Corner (#8) between the Leg Panels (#2and #3). See Step.1A.
- Turn over the Leg assembly and then attach two Screws (#53) to the top of the middle of the Leg assembly. See Step.1B.
- Attach four Leg Bases (#4) to Leg assemblies using four Screws (#51) per Leg Base. See Step.1C
- Repeat the above steps for the other Leg Panels (#2 and #3) Corners (#8) and Leg Base (#4).

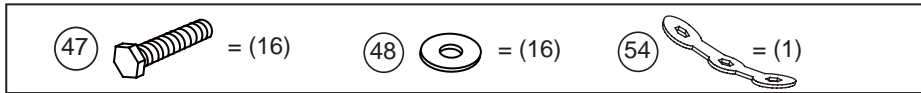

STEP 2

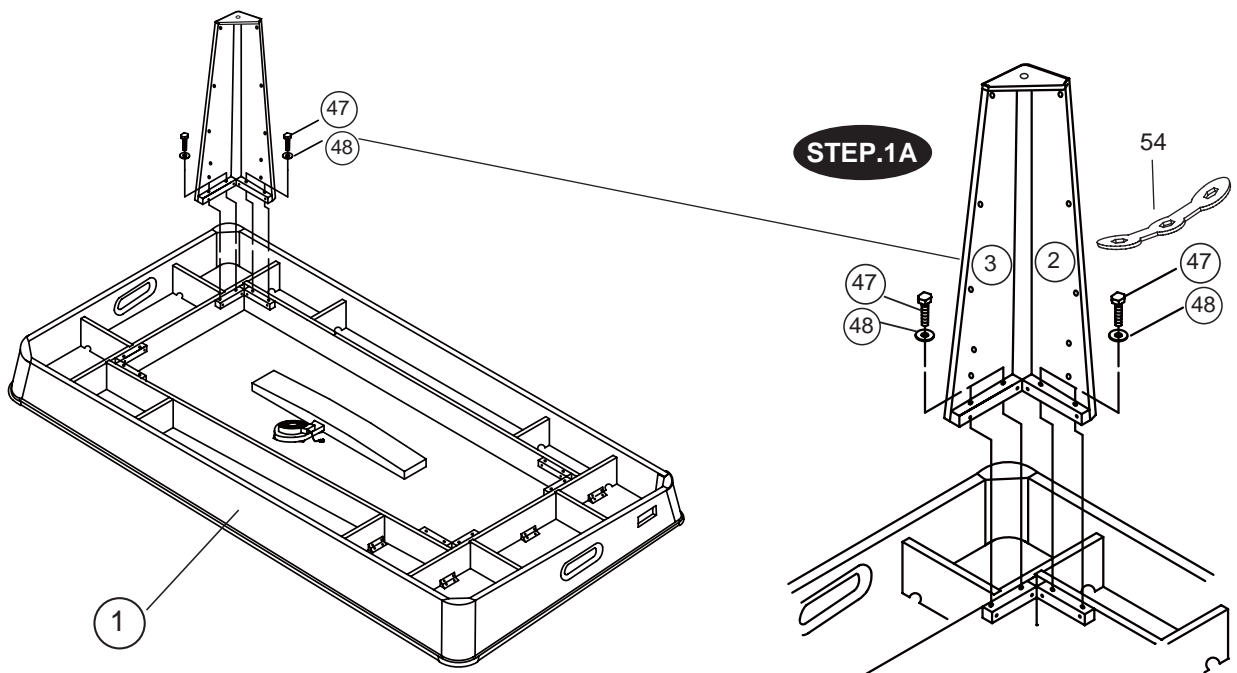

STEP 2:

- Attach the four Leg assemblies to the table (#1) using four Bolts (#47), eight Washers (#48) per leg assembly. See Step. 2A.

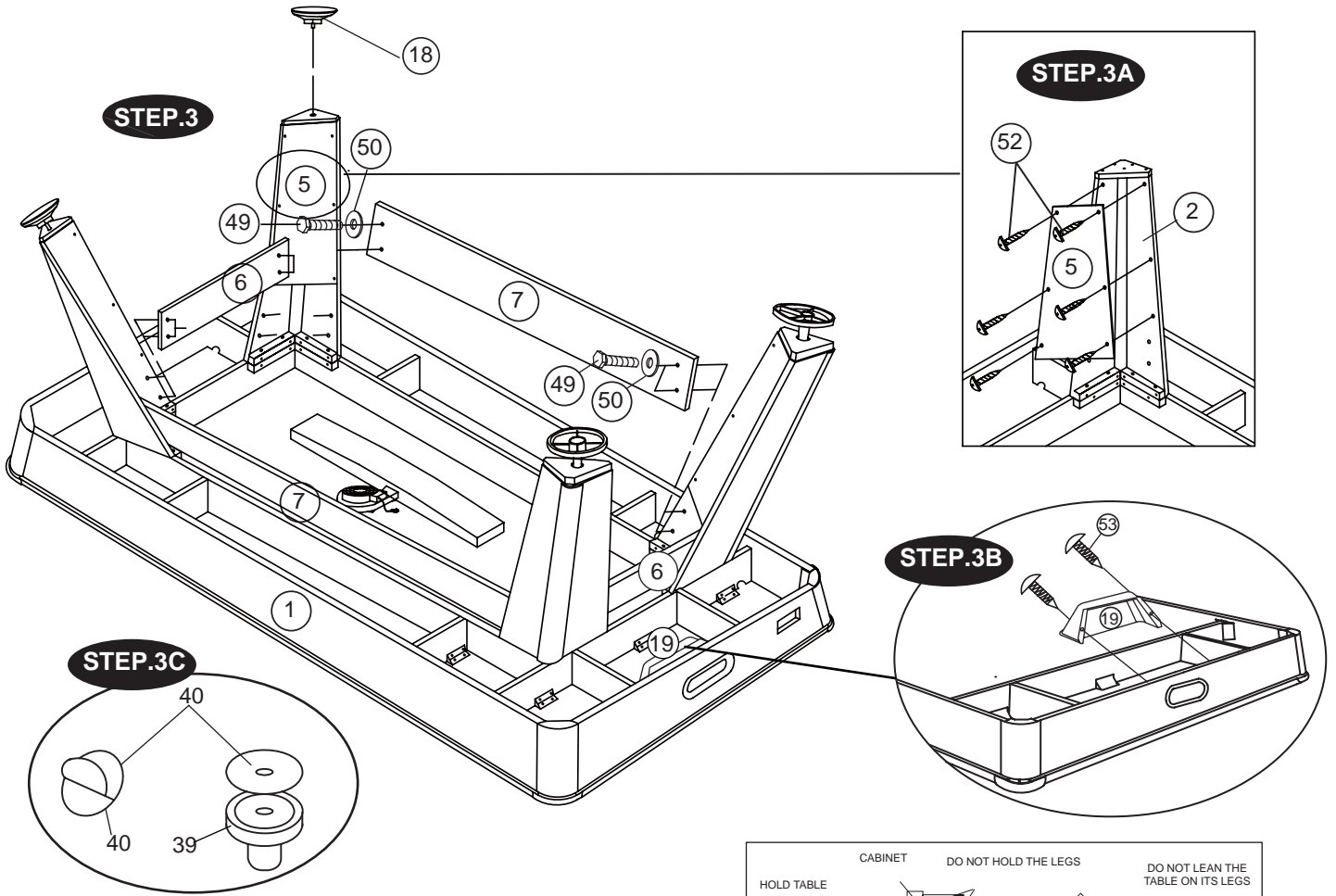
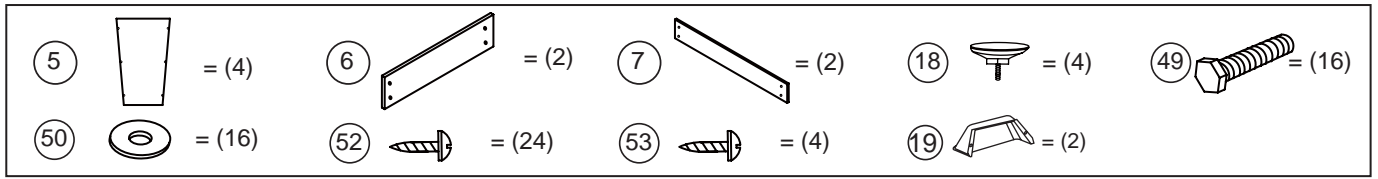

NOTE: A3 Felt Pads may already be attached to A1 Strikers.

STEP 3:

- Attach two Leg End Panels (#6) and two Leg Side Panels (#7) between two Legs using four Bolts (#49) with four washer (#50) per Leg End Panel and Side Panel.
- Attach four Leg Inside Panels (#5) to the Leg assemblies using six Screws (#52) per Leg Inside Panel. See Step.3A.
- [4] Attach the Goal Boxes (#19) to the Cabinet (#1) using two Screws (#53) per Goal Box. See Step.3B.
- Screw four Leg Levelers (#18) into the four Legs. See Step.3.
- You will need 4 or more adults for this step. Carefully lift the assembly off the floor and turn it over.
CAUTION: Make sure that you place the table squarely onto its legs or damage to the table may occur.
- Peel the backing off 40 Felt Pad and attach to 39 Pusher as shown in Step.3C.

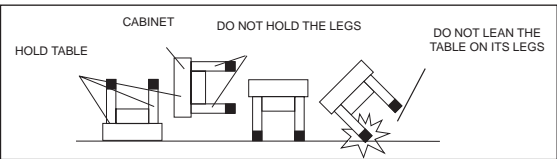

ELECTRONIC SCORER OPERATION:

1. Under the table, remove screw using a small phillips screwdriver and open the battery box. Insert 4(four) pcs AA batteries (not included) in the order of polarity as shown on the inside cover. Then close using a small phillips screwdriver.
(If the game will not be used for a long period of the time, we recommend that the batteries be removed).
2. Turn on the scorer using the on/off switch located on the scoring display. You will hear music and the Home and Visitor screens will show "00".
3. There is one pre-set period of 15 minutes which can be adjusted to 10 minutes, 5 minutes, or "No Time Limit" mode by pressing the "MINUTES" button.
4. Press the "START/RESET" button to start the game.
5. During Play - When "START/RESET" button is pushed, the following will occur:
 - Home and Visitor Score will reset to "00" and time will reset to it's original setting.
6. "Sound ON/OFF" - Press this button while the game is on to turn the sound OFF and ON.
7. Once Home or Visitor reaches "99" points, Home or Visitor display will stop the scorer and keep flashing. Please reset it by pressing the "START/RESET" button.

NOTE: If no score has been made for 15 minutes, the scoreboard will automatically turn off. You can turn it on again by pressing the "START/RESET" button. However, we suggest turning the power off when the game will not be used for an extended period of time.

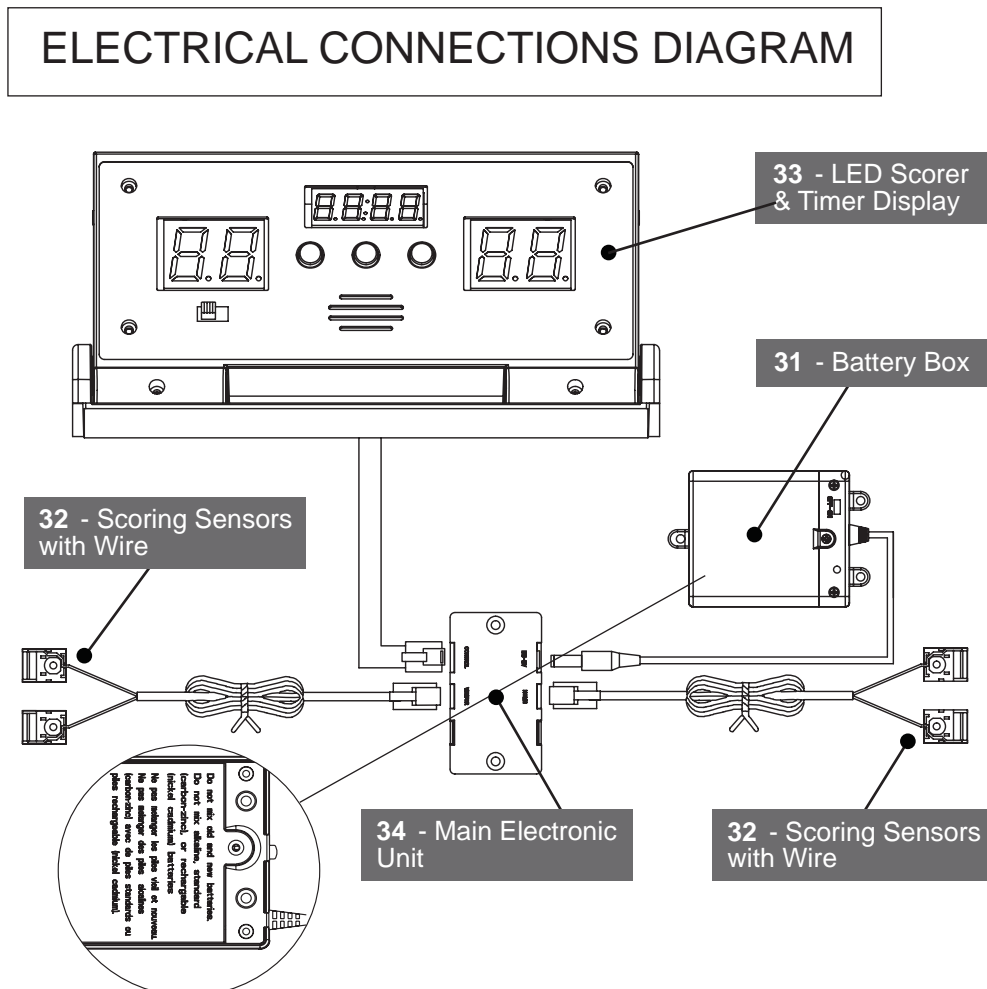

STEP 4:

- Connect the wires under the table as shown above.
- **⚠ WARNING!** Do not mix old and new batteries. Do not mix alkaline, standard (carbon - zinc), or rechargeable (nickel cadmium) batteries. Do not dispose of batteries in fire, batteries may explode or leak.

NOTE: Please clean the battery contacts of the device prior to battery installation. Make sure to remove batteries from the scorer when not used for an extended period of time. Remove used batteries promptly.